



## Modular Cooking Range Line 900XP 4 Electric Hot Plate Range on Electric Oven

ITEM # \_\_\_\_\_

MODEL # \_\_\_\_\_

NAME # \_\_\_\_\_

SIS # \_\_\_\_\_

AIA # \_\_\_\_\_



391041 (E9ECEH4QE0)

4-Hot Square Plates (4 kW each) electric Range on electric Oven (6 kW)

391167 (E9ECEH4QEN)

4-Hot Plate (4 kW each) electric Range on electric Oven (6 kW)

### Short Form Specification

Item No. \_\_\_\_\_

Unit to be Electrolux Professional 900XP four 4kW electric hot plate range on electric oven. Electric characteristics to be \_400V or \_230V. Unit to be installed on stainless steel feet with height adjustment up to 50 mm. Unit to have cast-iron hot plates hermetically sealed to the one-piece top. Oven chamber with 3 levels of runners to accommodate 2/1 GN shelves (2 steam pans). Unit to have ribbed, cast-iron oven base plate. Exterior panels of unit in Stainless steel with Scotch Brite finish. Extra strength work top in heavy duty 2 mm Stainless steel. Unit has right-angled side edges to allow flush-fitting junction between units.

### Main Features

- Unit to be mounted on stainless steel feet with height adjustment up to 50 mm. Unit can be easily mounted on cantilever systems.
- The four 4kW electric cast-iron hot plates are hermetically sealed to the one piece top and are featured with safety thermostat.
- Base compartment consists of an electric standard oven with 40 mm thick oven door for heat insulation, positioned beneath the base plate.
- Oven chamber with 3 levels of runners to accommodate 2/1 GN shelves (2 steam pans).
- Ribbed cast iron oven base plate.
- Oven to feature separate thermostats for top and bottom elements. Thermostat temperature adjustable from 110°C to 285°C.
- The special design of the control knob system guarantees against water infiltration.
- IPX5 water protection.
- Top configuration allows installation on ambient base only (not possible to install on refrigerated nor freezer base).

### Construction

- Unit is 930 mm deep to give a larger working surface area.
- All exterior panels in Stainless Steel with Scotch Brite finishing.
- AISI 304 stainless steel worktop, 2mm thick.
- Model has right-angled side edges to allow flush fitting joints between units, eliminating gaps and possible dirt traps.

### Included Accessories

- 1 of GN2/1 chrome grid for static oven PNC 164250

### Optional Accessories

- GN2/1 chrome grid for static oven PNC 164250
- Pair of cast iron plate bars for electric cooking top PNC 206056
- Junction sealing kit PNC 206086
- Kit 4 wheels - 2 swivelling with brake - it is mandatory to install Base support and wheels PNC 206135
- Flanged feet kit PNC 206136
- Frontal kicking strip for concrete installation, 800mm PNC 206148
- Frontal kicking strip for concrete installation, 1000mm PNC 206150

APPROVAL: \_\_\_\_\_



Experience the Excellence  
www.electroluxprofessional.com

- Frontal kicking strip for concrete installation, 1200mm PNC 206151
- Frontal kicking strip for concrete installation, 1600mm PNC 206152
- Pair of side kicking strips for concrete installation PNC 206157
- Frontal kicking strip, 800mm (not for refr-freezer base) PNC 206176
- Frontal kicking strip, 1000mm (not for refr-freezer base) PNC 206177
- Frontal kicking strip, 1200mm (not for refr-freezer base) PNC 206178
- Frontal kicking strip, 1600mm (not for refr-freezer base) PNC 206179
- Pair of side kicking strips (not for refr-freezer base) PNC 206180
- 2 panels for service duct for single installation PNC 206181
- 2 panels for service duct for back to back installation PNC 206202
- Kit 4 feet for concrete installation (not for 900 line free standing grill) PNC 206210
- Water column with swivel arm (water column extension not included) PNC 206289
- Water column extension for 900 line PNC 206290
- Chimney upstand, 800mm PNC 206304
- Back handrail 800 mm PNC 206308
- Back handrail 1200 mm PNC 206309
- Base support for feet or wheels - 800mm (700/900) PNC 206367
- Base support for feet or wheels - 1200mm (700/900) PNC 206368
- Base support for feet or wheels - 1600mm (700/900) PNC 206369
- Base support for feet or wheels - 2000mm (700/900) PNC 206370
- Rear paneling - 800mm (700/900) PNC 206374
- Rear paneling - 1000mm (700/900) PNC 206375
- Rear paneling - 1200mm (700/900) PNC 206376
- Chimney grid net, 400mm (700XP/900) PNC 206400
- Scraper for ribbed plate fry tops - kit includes knife blades for both smooth and ribbed surface (only for 391041) PNC 206420
- Side handrail-right/left hand (900XP) PNC 216044
- Frontal handrail, 800mm PNC 216047
- Frontal handrail, 1200mm PNC 216049
- Frontal handrail, 1600mm PNC 216050
- 2 side covering panels for free standing appliances PNC 216134
- Large handrail - portioning shelf, 800mm PNC 216186

Front

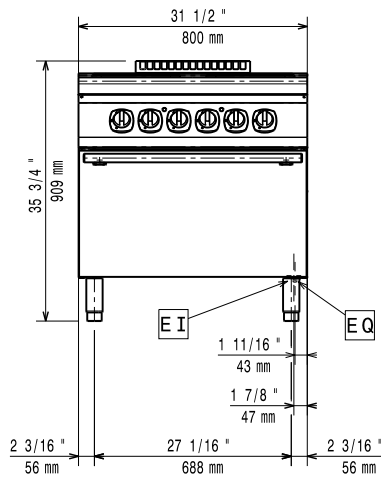

Side

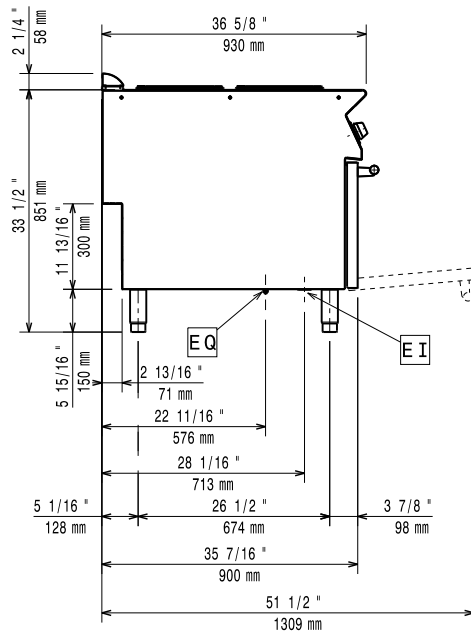

EI = Electrical inlet (power)  
 EQ = Equipotential screw

Top

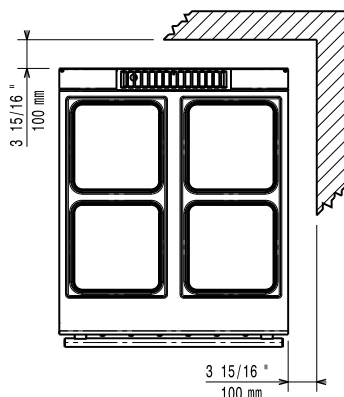

### Electric

#### Supply voltage:

391041 (E9ECEH4QE0)

380-400 V/3N ph/50/60 Hz

391167 (E9ECEH4QEN)

230 V/3 ph/50/60 Hz

#### Electrical power max.:

22 kW

#### Total Watts:

22 kW

#### Predisposed for:

391041 (E9ECEH4QE0)

380-400V 3N- 50/60Hz  
 20-22kW

### Key Information:

#### Front Plates Power:

4 - 4 kW

#### Back Plates Power:

4 - 4 kW

#### Front Plates dimensions:

300x300 300x300

#### Back Plates dimensions:

300x300 300x300

#### Oven Heat Input:

6 kW

#### Oven working Temperature:

110 °C MIN; 285 °C MAX

#### Oven Cavity Dimensions

##### (width):

575 mm

#### Oven Cavity Dimensions

##### (height):

300 mm

#### Oven Cavity Dimensions

##### (depth):

700 mm

#### External dimensions, Width:

800 mm

#### External dimensions, Depth:

930 mm

#### External dimensions, Height:

850 mm

#### Net weight:

391041 (E9ECEH4QE0)

120 kg

391167 (E9ECEH4QEN)

145 kg

#### Shipping weight:

391041 (E9ECEH4QE0)

142 kg

391167 (E9ECEH4QEN)

170 kg

#### Shipping height:

391041 (E9ECEH4QE0)

1080 mm

391167 (E9ECEH4QEN)

1120 mm

#### Shipping width:

1020 mm

#### Shipping depth:

860 mm

#### Shipping volume:

391041 (E9ECEH4QE0)

0.95 m<sup>3</sup>

391167 (E9ECEH4QEN)

0.98 m<sup>3</sup>

If appliance is set up or next to or against temperature sensitive furniture or similar, a safety gap of approximately 150 mm should be maintained or some form of heat insulation fitted.

#### Certification group:

391041 (E9ECEH4QE0)

EH94O

391167 (E9ECEH4QEN)

N9CEI