

## Digital Cabinets

### 2-half door Freezer, -22-18°C, AISI 304, R290

ITEM # \_\_\_\_\_

MODEL # \_\_\_\_\_

NAME # \_\_\_\_\_

SIS # \_\_\_\_\_

AIA # \_\_\_\_\_

**790479 (ACAFB3)**

2-half door Freezer, -22-18°C, AISI 304, R290 - ASIA

### Short Form Specification

#### Item No.

2-half door Freezer, -18-22°C. Structure in stainless steel. High-density expanded polyurethane insulating foam, 85 mm in thickness, with cyclopentane injection. Lockable doors, magnetic door seal and removable triple air chamber gasket. Digital control panel. Built-in refrigeration unit; coated finned evaporator with anti-corrosion treatment, completely automatic defrosting and automatic evaporation of defrost water. Internal LED light. For ambient temperatures up to 38 °C. R290 refrigerant gas for the lowest environmental impact - CFC and HCFC free.

### Main Features

- Completely automatic defrosting and automatic evaporation of defrost water.
- Doors are reversible and self closing.
- Removable triple air chamber gasket to guarantee hygiene and perfect insulation.
- Forced air circulation for rapid cooling and an even temperature distribution.
- Internal LED light for perfect internal visibility.
- Lockable doors.
- Digital control panel for temperature and parameter setting as well as to activate defrosting when necessary.
- Large storage area suitable to contain 2/1 GN grids.
- Performance guaranteed at ambient temperatures of +38°C.
- Moulded inner liner for high hygiene and cleanability.
- Electronics resistant to high voltage peaks.
- Coated finned evaporator with anti-corrosion treatment to avoid corrosion and to guarantee everlasting operation.
- Adjustable temperature range from -18 °C to -22 °C to suit meat, fish and dairy storage requirements.
- HACCP compliant digital control: when temperature exceeds critical limits, acoustic and visual alarms are activated.
- Door frame heater avoids condensation build-up around the door frame.

### Construction

- Developed and produced in ISO 9001 and ISO 14001 certified factory.
- Rounded internal corners for ease of cleaning.
- Internal panels and fittings in AISI 304 Stainless Steel.
- Built-in compressor.
- Magnetic door seal to guarantee perfect closure.
- External doors, front, back and side panels in AISI 304 Stainless Steel.

### Sustainability



- CFC and HCFC-free insulation.
- High-density expanded polyurethane insulating foam, 85 mm in thickness, with cyclopentane injection for long-term insulation and energy saving.
- Hydrocarbon refrigerant gas for the lowest environmental impact - CFC and HCFC free.
- Low energy consumption thanks to high efficiency components, insulation and optimized airflow.

### Optional Accessories

- Kit of 2/1GN shelf for Cabinets PNC 880624  with solid door

APPROVAL: \_\_\_\_\_

Front

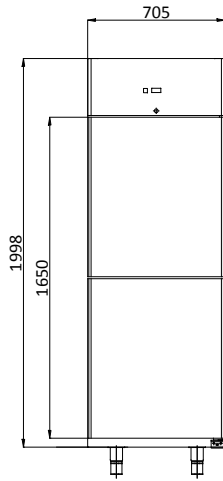

Side

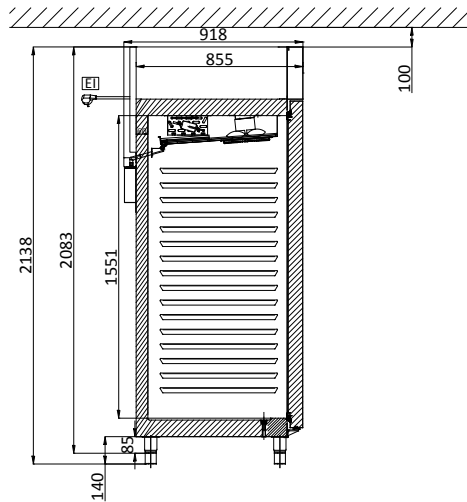

EI = Electrical inlet (power)

Top

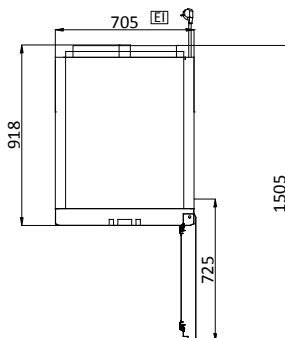

#### Electric

##### Supply voltage:

790479 (ACAFB3)

220-240 V/1N ph/50 Hz

##### Electrical power max.:

0.25 kW

#### Key Information:

##### Gross capacity:

550 lt

##### External dimensions, Width:

705 mm

##### External dimensions, Depth:

918 mm

##### External dimensions, Depth with Doors Open:

1505 mm

##### External dimensions, Height:

2085 mm

##### Number and type of doors:

2x1/2 Full

##### Number and type of grids (included):

3 - GN 2/1

Stainless Steel AISI 304

##### Type of external material:

Scotch Brite

##### Type of internal material:

304 AISI

##### Number of positions & pitch:

16; 75 mm

#### Refrigeration Data

##### Compressor power:

1/4 hp

##### Operating temperature min.:

-22 °C

##### Operating temperature max.:

-18 °C

##### Operating mode:

Ventilated

#### Sustainability

##### Refrigerant type:

R290